

COMMUNICATION MICROPHONE

MC-80

INSTRUCTION MANUAL

FEATURES

The MC-80 is designed for use with a wide range of communication equipment.

UP/DOWN frequency switching and a preamplifier are provided. The silver and dark gray colors of the microphone match other communication equipment.

BEFORE OPERATION

1. Power supply

Since the MC-80 uses an electret condenser microphone, power is required for operation.

- (1) Obtain four (4) common "AA" cells.
- (2) Remove the lid as shown in Fig. 2. Install the batteries observing correct polarity. Replace the lid.
- (3) After the batteries are installed, place the POWER switch ON and verify that the LED lights.

2. Connection to transceiver

As shown in Fig. 1, the MC-80 has a standard Kenwood 8-pin MIC connector. Fig. 3 shows the connection between the transceiver and the microphone. Connecting the microphone to a transceiver with 4-pin or 6-pin MIC jack requires an optional adapter plug. Connection with equipment other than Kenwood may require either reconnection of the plug, or a different type plug. Refer to the instruction manual for necessary wiring details.

3. Operation

Turning the POWER switch on lights the POWER ON LED to show the mic is operating.

(1) Volume adjustment

A potentiometer to control the sound output level is located at the rear of the mic stand panel.

Adjusting the POT varies the output from 0 to 10 mV. A -50 dB setting (approx. 3.3 mV output) is preset at the factory. For normal operation, use this setting.

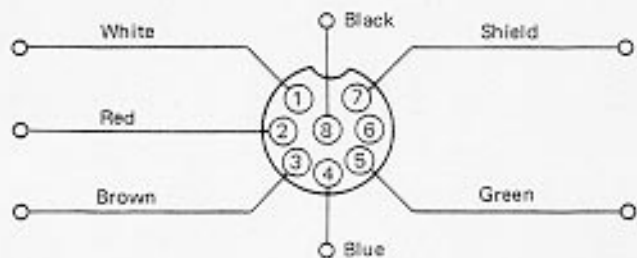
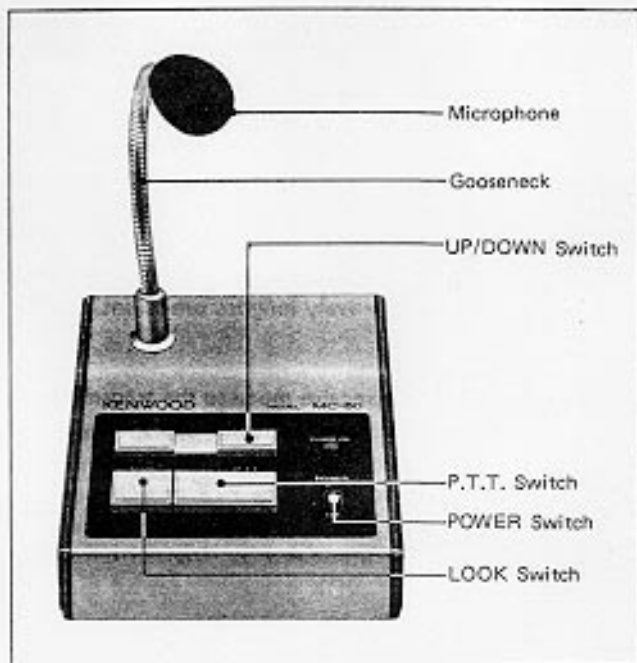

Fig. 1.

Transceiver	Mic jack	Mic connection and adapter	Power supply
TS-430, TS-930 TM-201, TM-401 TS-660, TW-4000 TS-780	8 pin	Adapter not needed. Direct.	Use 4 "AA" batteries.
TR-9000 series TR-7700/8400 series	6 pin	Use MJ-86 adapter.	
TR-7200/7500 series TS-120/130 series TS-520/530 series TS-820/830 series	4 pin	Use MJ-84 adapter.	
Transceiver of another manufacturer	Refer to the transceiver owners manual: change the wiring or use an adapter.		

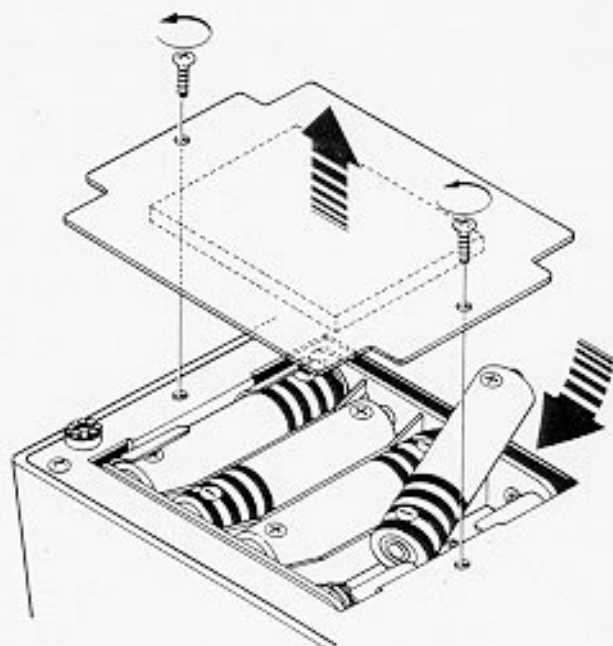

Fig. 2 Battery installation

(2) PTT and LOCK switch operation

Use the PTT or LOCK switch to transmit. Holding the PTT switch depressed allows transmission and releasing the switch returns operation from transmission to reception. Depressing the LOCK switch once allows transmission. The transmit mode remains ON after the switch is released. Depressing the switch again switches from the transmit mode to receive mode. The PTT switch is used for rapid QSO exchanges. The LOCK switch is used for relatively long transmissions.

(3) VOX operation

Switching from the receive mode to the transmit mode by your voice is called VOX (voice operated transmit) operation.

There is no need to touch the PTT or LOCK switch. Whether or not the VOX operation is possible depends upon whether the transceiver or transmitter used is VOX-equipped. For VOX operation, set up the transceiver and turn on the MC-80 power.

Speaking into the microphone automatically switches the associated transceiver to transmission. When you stop speaking, the transceiver automatically returns to the receive mode. Usually, a relay is used in the transceiver for switching between transmission and reception. Relay "click" may be heard from the transceiver when switching from transmit to receive or vice-versa. For VOX operation details, refer to the transceiver instruction manual.

(4) Modulation level

Since the MC-80 employs an electret condenser microphone, speaking close to the microphone may sometimes result in reduced clarity. For normal operation, maintain 10–15 cm distance to the microphone. The optimum modulation level may vary depending upon the transceiver and operating conditions. Adjust the transceiver MIC level control, referring to the transceiver instruction manual.

(5) Output impedance

The following are typical impedance of Kenwood communications equipment:

HF equipment 50k ohms
VHF & UHF equipment 500 ohms

The MC-80 is set for 680 ohms so it can be used with all equipment types.

(6) UP/DOWN switch operation

Equipment having a remote UP and DOWN tuning system can be controlled from the UP/DOWN microphone. For equipment without remote tuning, the mic UP/DOWN switches are not used.

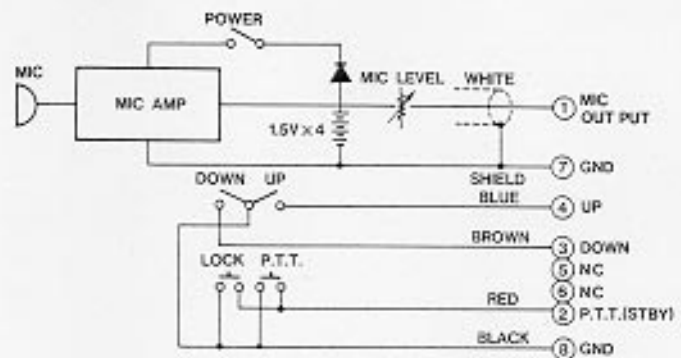

Fig. 3. MC-80 block diagram & mic plug connection

■ PRECAUTIONS

1. Do not disassemble or otherwise modify the mic assembly, or the original mic characteristics may be altered.
2. The microphone is delicate. Be sure not to jar or shock the microphone element.
3. Ensure that power is turned off when the mic is not used.
4. When the battery voltage drops due to depletion, the power output will drop and distribution may occur. Replace the battery for these indications.

■ SPECIFICATIONS

Mic unit	Omnidirectional electret condenser.
Output impedance	Approx. 700 ohms \pm 30% at 1,000 Hz
Sensitivity (0 dB = 1 V/ μ bar, 1,000 Hz)	-40 dB \pm 6 dB (VR MAX.)
Sensitivity when shipping	-50dB \pm 6 dB
Frequency characteristic	200 ~ 7,000 Hz (\pm 6 dB)
Power supply	Batteries 6V (1.5 V x 4) (Batteries not supplied)
Current consumption	Approx. 10mA (Batteries can be used more than 500 hours)
Weight	700 g

A product of
TRIO-KENWOOD CORPORATION
17-5, 2-chome, shibuya, shibuya-ku Tokyo 150, Japan

TRIO-KENWOOD COMMUNICATIONS
1111 West Walnut Street, Compton, California 92220, U.S.A.
TRIO-KENWOOD COMMUNICATIONS, GmbH
D-8378 Steinhilf, 75 Industriestrasse 8A, West Germany
TRIO-KENWOOD ELECTRONICS, N.V.
Lauvensteinweg 504, B-1130 Zaventem, Belgium
TRIO-KENWOOD (AUSTRALIA) PTY. LTD.
4E Woodcock Place, Lane Cove N.S.W. 2086, Australia